

# TINED WEEDER

**AS 300 M1, AS 450, AS 600 M1, AS 900 M1,  
AS 1200 M1**

**OPERATOR MANUAL**



**PLEASE READ CAREFULLY BEFORE COMMISSIONING!**

Translation of the original operating manual

Version: 3.0 EN-UK; item number: 00605-3-001025



## TABLE OF CONTENTS

<b>EC DECLARATION OF CONFORMITY</b> .....	<b>4</b>
<b>1 IDENTIFICATION OF THE IMPLEMENT</b> .....	<b>5</b>
<b>2 SERVICE</b> .....	<b>5</b>
<b>3 WARRANTY</b> .....	<b>6</b>
3.1 Warranty activation.....	6
<b>4 SAFETY INFORMATION</b> .....	<b>6</b>
4.1 Intended use.....	6
4.2 General safety-related instructions and accident prevention regulations.....	7
4.3 Risks involved with use (mounted implement).....	8
4.4 Hydraulic system.....	8
4.5 Risks involved with maintenance (maintenance, tyres).....	9
<b>5 SAFETY SIGNS</b> .....	<b>10</b>
<b>6 OPERATING MANUAL</b> .....	<b>12</b>
6.1 Implement description.....	12
6.1.1 Instructions on the AS 300 M1.....	12
6.2 Mounting on the tractor.....	12
6.3 Safe parking AS 300 M1.....	12
6.4 Safe parking AS 450 / AS 600 M1 / AS 900 M1 rigid.....	13
6.5 Safe parking AS 900 M1 scissors folding / AS 1200 M1.....	14
6.6 Test folding of the Tined Weeder (with hydraulic folding).....	15
6.7 Working position and setting the working depth.....	15
6.8 Hydraulic tine adjustment.....	17
<b>7 ROAD TRANSPORT</b> .....	<b>17</b>
7.1 Transport on public roads (general information).....	17
7.2 Calculation of the weight ratios for axle loads on the tractor and ballast weights.....	17
7.3 Table for the weight ratios.....	19
<b>8 MAINTENANCE AND CARE</b> .....	<b>19</b>
8.1 General maintenance instructions.....	19
8.2 Regular maintenance work.....	20
8.3 Changing the tines.....	20
8.4 Repairs and service.....	20
<b>9 TECHNICAL DATA</b> .....	<b>21</b>
9.1 Combination options for the Tined Weeder with pneumatic seeders.....	22
<b>10 HYDRAULIC DIAGRAM</b> .....	<b>23</b>
10.1 AS 450, AS 600 M1, AS 900 M1 rigid (single-acting).....	23
10.2 AS 450, AS 600 M1, AS 900 M1 rigid (double-acting).....	23
10.3 AS 900 M1 Scissors folding, AS 1200 M1.....	24
<b>11 LIGHTING CIRCUIT DIAGRAM</b> .....	<b>24</b>
<b>12 DECOMMISSIONING, STORAGE AND DISPOSAL</b> .....	<b>25</b>
12.1 Decommissioning the implement.....	25
12.2 Storage of the implement.....	25
12.3 Disposal.....	25

<b>13</b>	<b>CROPPING TIPS FOR USING THE TINED WEEDER.....</b>	<b>26</b>
<b>14</b>	<b>INFORMATION ON NATURE CONSERVATION AND ENVIRONMENTAL PROTECTION .....</b>	<b>27</b>
14.1	Reduction of noise pollution during use.....	27
14.2	Energy-efficient use .....	27
14.3	Recyclable raw materials during disposal.....	27
<b>15</b>	<b>ACCESSORIES .....</b>	<b>27</b>
15.1	Warning signs and LED lighting .....	27
15.2	Accessories kit AS 600 to AS 900 .....	27
15.3	Accessories kit AS 900 to AS 1200 .....	27
15.4	Accessories kit for PS 120 – 300 .....	28
15.5	Accessories kit for ES and MDP .....	28
15.6	Accessories kit for PS 120 – 500 with headstock .....	28
15.7	Hydraulic tine adjustment.....	29
15.8	Platform kit for AS .....	29
15.9	Accessories kit for a second feeler wheel pair.....	29
<b>16</b>	<b>SPARE PARTS.....</b>	<b>29</b>
<b>17</b>	<b>INDEX.....</b>	<b>30</b>



## EC Declaration of Conformity

Manufacturer: **APV – Technische Produkte GmbH**  
Dallein 62  
AT - 3753 Hötzelstdorf

hereby declares that the mounted implement series described in the following complies with the applicable basic safety and health requirements of the above-mentioned Directives in terms of its concept and design as well as the versions put on the market.

This declaration loses its validity if there are any changes to the implement that are not approved by **APV – Technische Produkte GmbH**.

Name of the mounted implement **Tined weeder**  
series:  
**AS 300 M1 | AS 450 | AS 600 M1**  
**AS 900 M1 | AS 900 M1 Scissors folding | AS 1200 M1**

Year of manufacture: from 2022

Serial number: Starting from 07034-01000 | 07042-01000 | 07017-01000  
07016-01000 | 07021-01000 | 07015-01000

Relevant Directives: 2006/42/EC EC Machinery Directive

For the planing, design, construction and marketing of the implement, the following harmonised European standards were applied:

EN ISO 12100:2010	Safety of machinery – General principles for design; risk assessment and risk reduction
EN ISO 4254-1:2015	Safety requirements for agricultural machinery – Part 1: General requirements
EN ISO 13854:2019	Safety of machinery – Minimum gaps to avoid crushing of parts of the human body
EN ISO 13857:2019	Safety of machinery - Safety distances to prevent hazard zones being reached by upper and lower limbs
EN 60204-1:2018	Safety of machinery – Electrical equipment of machines – Part 1: General requirements

The special technical documents belonging to the implement in accordance with Appendix VII, Part A have been prepared.

Responsible for the technical documentation: APV - Technische Produkte GmbH

Dallein / Hötzelstdorf, 04/2026



In. Karl Heinz Steindl  
Managing Director (authorised person in der EU)

# 1 IDENTIFICATION OF THE IMPLEMENT

The Tined Weeder can be clearly identified by the following information on the type plate.

- Designation
- Model
- Production number

## Position of the type plate

The type plate is found on the main frame beside the top link coupling point (see Figure 1).



Figure 1

The following image (Figure 2) shows the layout of the type plate:

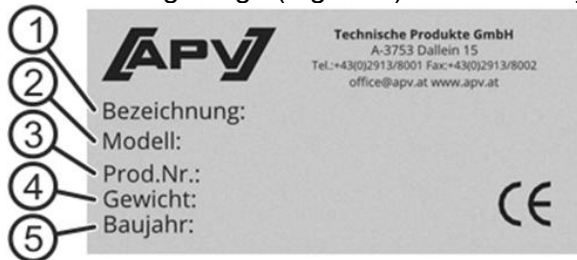

Figure 2

The data on the type plate have the following meaning:

- 1: Designation
- 2: Model
- 3: Product number / serial number
- 4: Weight
- 5: Year of manufacture



## NOTE!

In cases of inquiries or warranty claims, please always tell us the production number / serial number of your implement.



## CAUTION!

Misprints, errors and omissions excepted!

# 2 SERVICE

Please contact our service address in the following cases:

- If you still have questions regarding the handling of the tined weeder despite the information provided in this operating manual.
- For spare parts orders.
- To order maintenance and servicing work.

## Service address:

APV - Technische Produkte GmbH  
Zentrale: Dallein 62  
A-3753 Hötzelzdorf  
AUSTRIA

Telephone: +43 2913 8001-5500  
Fax: +43 2913 8002  
Email: [service@apv.at](mailto:service@apv.at)  
[www.apv.at](http://www.apv.at)

## 3 WARRANTY

Please check the implement for any transport damage immediately upon receipt. Later claims regarding transport damage can no longer be considered.

We provide a six-month factory warranty as of the date of delivery (your invoice or the delivery slip serve as a warranty certificate).

This warranty is applicable for cases of material or construction faults and does not include parts that are damaged by normal or excessive wear.

The warranty expires

- if damage is caused by external forces.
- in cases of operating errors.
- if the kW/HP limits are significantly exceeded.
- if the implement is modified, expanded or equipped with third-party spare parts without our permission.

### 3.1 WARRANTY ACTIVATION

Every APV implement must be registered immediately after delivery. The registration activates the claim for warranty services and APV can guarantee the best service.

To activate the warranty for your implement, simply scan the QR code with your smartphone - you will then be taken directly to the service area on our website.



Of course, you can also activate the warranty through our website [www.apv.at](http://www.apv.at) in the service area.

## 4 SAFETY INFORMATION

**This chapter contains general rules of conduct for the intended use of the implement and safety-related information that should always be observed for your safety.**

The list is very extensive, and some of the information does not apply exclusively to the delivered implement. However, the summary of the information often reminds you of unconsciously neglected safety regulations for the everyday operation of machines and implements.

### 4.1 INTENDED USE

The implement is designed solely for normal use in agricultural operations (intended use).

Any use beyond that is deemed to be improper. The manufacturer is not liable for any resulting damage, the operator alone bears the associated risk.

Intended use also includes compliance with the conditions for operation, maintenance, and repairs prescribed by the manufacturer.

The implement may only be used, maintained and repaired by persons who have relevant experience and were instructed on the dangers. The safety instructions must also be handed over to other users.

The applicable domestic and international accident prevention regulations as well as the other generally safety-related, occupational health and road traffic regulations must also be observed.

The manufacturer is not liable for any damage resulting from unauthorised modifications and the use of components and auxiliary parts.

The implement is intended for outdoor operation in dry weather, within a temperature range from +5 °C to 40 °C. Water penetration must be avoided. Do not use the implement in rainy conditions!

## 4.2 GENERAL SAFETY-RELATED INSTRUCTIONS AND ACCIDENT PREVENTION REGULATIONS

- **The operator has read and understood this operating manual before handling the implement.**
- **The operator must train and instruct their personnel. The personnel must have read and understood this operating manual before handling the implement.**
- Always keep the operating manual close to the implement for reference purposes.
- When passing on the implement, be sure to pass on the operating manual.
- Do not use the implement if you are tired or under the influence of drugs, alcohol or medication.
- **Before each use, the folding device and its safety devices (securing chain) must be checked for proper function and effect.**
- Check the implement and the tractor for road and operational safety before every use!
- Observe the generally applicable safety and accident prevention regulations!
- The warning and information signs applied to the implement provide important instructions for safe operation, observe them for the sake of your own safety!
- Observe the respective regulations when using public roads!
- Before starting work, get to know all of the equipment and operating elements as well as their functions. It is too late to do so during operation!
- The user should wear close-fitting clothing. Avoid wearing loose clothes!
- Keep the implements clean to reduce the risk of fire!
- Check the surrounding area before starting up and operating the implement! (Children!) Ensure sufficient visibility!
- It is not allowed to carry passengers on the implement during operation and transport!
- The implement must be coupled according to the instructions and only onto the specified devices!
- Special care must be taken when coupling and uncoupling implement to and from the tractor!
- When mounting and dismounting, put the support devices in their respective positions! (Stability)
- Always attach ballast weights at the intended attachment points according to the specifications!
- Observe the permissible axle load, total weight and transport dimensions!
- Transport equipment - e.g. lighting, warning signs and any protective equipment, must be checked and mounted!
- Triggers for fast couplers must be hanging loosely and must not trigger themselves when lowered.
- Never leave the driver's platform while driving!
- The driving behaviour, steering and braking capacity are also affected by mounted or towed implements and ballast weights. For this reason, always ensure sufficient steering and braking capacity!
- When driving in curves, take account of the wide radius and/or the centrifugal mass of the implement!
- The implement may only be operated when all of the protective devices are installed and in safety position!
- It is forbidden to stand in the working area of the implement!
- Do not stand near rotating and swivelling parts of the implement!
- Hydraulic folding frames may only be actuated when nobody is standing in the swivelling range.
- There are pinch and shear points on externally powered (e.g. hydraulic) parts!
- On implements with manual folding, always ensure that the implement is stable!
- For implements that are driven at high speeds with soil-driven tools - Danger after lifting due to the still rotating centrifugal mass! Only approach the implement when it has come to a standstill!
- Before exiting the tractor, lower the implement onto the ground, switch off the motor and remove the ignition key!
- Standing between the tractor and the implement is forbidden unless the vehicle is secured against rolling away using the parking brake and/or with wheel chocks!
- Folded frames and lifting devices must be locked in transport position!
- Packer hooks must be swivelled in and locked before road transport!
- Lock the track markers in transport position!
- The view on the tined weeder and the hazardous movement area must be clear (to check the procedure).

- Cleaning is recommended as specified in the maintenance manual. The procedures in the maintenance manual must be observed and personal protective equipment must be used.
- Working under the implement is forbidden.
- The implements and lines must be checked regularly by the operator (before every use) for any fractures and cracks, chafe marks, leaks, loose bolts and connections, vibrations, unusual sounds, and to ensure they function correctly.
- Safety glasses and hearing protection should be used.
- During assembly, the operator must ensure that the requirements for the tractor in terms of the power, axle loads and weight distribution as specified in the operating manual are met and that the connections specified in the operating instructions are made correctly.
- When mounting the implement, the operator must ensure that connections to the tractor hydraulic system are clean and carefully connected.
- When performing the work passes, the tractor's forward speed must be maintained as specified in the operating manual. This can be between 6 and 12 km/h.
- Additional lighting (e.g., flashlight) should be used for repair or maintenance work if necessary.

### **4.3 RISKS INVOLVED WITH USE (MOUNTED IMPLEMENT)**

- Before mounting and dismounting implements on the three-point linkage, move the operating devices into the position that excludes unintentional lifting or lowering!
- For three-point mounting, the mounting categories of the tractor and the implement must match or be adapted!
- There is a risk of injury due to crushing and shearing points in the area of the three-point linkage!
- Do not stand between the tractor and the implement when actuating the external controls for the three-point mounting!
- When the implement is in transport position, always ensure that the tractor three-point linkage is sufficiently locked to the sides!
- When driving on roads with the implement lifted, the operating lever must be locked against lowering!
- When mounting the tined weeder, the operator must ensure that there is a metallic connection made to the tractor.
- The operator must ensure that no one is standing close to the tined weeder when it or its components are being moved by the tractor hydraulic system or when the side wings are being lifted or lowered. Visual check by the driver!
- When driving on roads, which is only permitted with the tined weeder lifted and with folded side wings, the control block on the hydraulic cylinder prevents lowering of the tined weeder as well as of the folded up side wings (additionally secured with a chain). This is also ensured in case of failure of the tractor hydraulic system.

### **4.4 HYDRAULIC SYSTEM**

- The hydraulic system is under high pressure!
- When connecting hydraulic cylinders and motors, the specified connection of the hydraulic hoses must be observed!
- When connecting the hydraulic hoses to the tractor hydraulic system, make sure that the hydraulic system on the tractor and implement side is unpressurised!
- For hydraulic function connections between the tractor and the implement, coupling sleeves and connectors should be marked to rule out operating errors! If the connections are interchanged, the function will be inverted (e.g. lifting/lowering)! – Danger of accident!
- Inspect the hydraulic hose lines at regular intervals and replace in case of damage or wear! The replacement lines must comply with the technical requirements of the implement manufacturer!
- Due to the risk of injury, use suitable tools when searching for leaks!
- Liquids escaping under high pressure (hydraulic oil) can penetrate skin and cause serious injuries! Consult a doctor immediately in case of injury! (Risk of infection!)
- Before working on the hydraulic system, park the implement, depressurize the system and switch off the motor!

- 
- The securing chain should only be unhooked when it is relieved of tension! (cylinder must be filled with oil)

#### **4.5 RISKS INVOLVED WITH MAINTENANCE (MAINTENANCE, TYRES)**

- Maintenance, repair, and cleaning work as well as the elimination of malfunctions should always be performed when the drive is switched off and the motor is at a standstill! – Remove the ignition key!
- Check the nuts and bolts regularly for tight fit and retighten if necessary!
- When performing maintenance on the lifted implement, always ensure safety through suitable support elements!
- When changing work tools with sharp edges, always use suitable tools and gloves!
- Properly dispose of oils, grease and filters!
- Always cut the power supply when working on the electrical system!
- When performing electrical welding work on the tractor and mounted implement, disconnect the cable on the generator and the battery!
- Spare parts must at least comply with the technical requirements specified by the implement manufacturer! This is ensured with original parts!
- Cleaning must be performed with water or compressed air. Cleaning must be carried with the implement lowered, shut down and secured to prevent it being switched on again.
- When working on the tyres, it must be ensured that the implement is safely parked and secured against rolling away (wheel chocks).
- The mounting of wheels and tyres requires sufficient knowledge and proper installation tools.
- Repair work on the tyres may only be performed by specialists and with suitable installation tools.
- Check the tyre pressure regularly. Observe the prescribed inflation pressure.

## 5 SAFETY SIGNS

Pay special attention to the stickers on the implement, as they warn you of specific dangers!

 <p>Standing in the danger zone (swivelling range) is forbidden!</p>	 <p>Do not stand on the implement while driving!</p>	 <p>Always switch off the engine and remove the key before maintenance work!</p>	 <p>Read and observe the operating manual before operating the implement!</p>
 <p>Lift the implement off the ground and slowly fold or unfold.</p>	 <p>Loading hooks When loading the implement, attach the ropes or chains to these points!</p>	 <p>Be careful with escaping high-pressure liquids! Observe the instructions in the operating manual!</p>	 <p>Do not stand between the machines when connecting the implements and actuating the hydraulic system!</p>



Do not climb onto rotating parts, use the intended access ladders!



Caution, risk of crushing!  
Never reach into the crushing danger zone as long as the parts can still move!

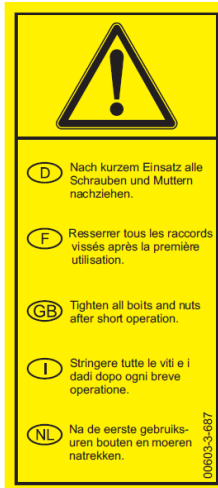

After a short period of operation, re-tighten all bolts and nuts.

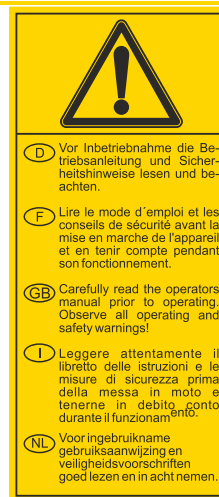

Read and observe the operating manual before operating the implement!



Caution, risk of crushing!  
Standing in the danger zone (swivelling range) is forbidden!

## 6 OPERATING MANUAL

### 6.1 IMPLEMENT DESCRIPTION

The Tined Weeder AS 300 M1 | AS 450 | AS 600 M1 | AS 900 M1 | AS 900 M1 Scissors folding | AS 1200 M1 is a soil tillage implement that can be hitched onto a towing vehicle on the three-point hitch.

#### 6.1.1 INSTRUCTIONS ON THE AS 300 M1

The AS 300 M1 tined weeder is not foldable and has no hydraulic system.

Please note that the AS 300 M1 may only be combined with the Single Disc Spreader ES and Multi-Metering System MDP.

### 6.2 MOUNTING ON THE TRACTOR

Under difficult operating conditions, additional wheel weights can be useful. Please also refer to the operating manual from the tractor manufacturer.

The tractor should be equipped with sufficient ballast weight at the front to ensure the steering and braking capacity. At least 20% of the empty vehicle weight is required on the front axle.

The lifting struts must be adjusted to the same height on the left and on the right. The implement must be mounted on the 3-point linkage of the tractor.

Mount the top link so that it slants down towards the tractor during operation. (Observe the specifications from the tractor manufacturer.)

Adjust the side rods so that the implement can swing freely on the field, but is fixed when the implement is lifted.

### 6.3 SAFE PARKING AS 300 M1

On machine variant AS 300 M1 (Figure 3), first lower the rear parking support (as shown in Figure 8). The support leg must be secured with the spring cotter on the bolt to prevent accidental loosening. The parking area must be suitable for parking the implement, i.e. have a firm and level surface so that the stands do not sink in and the harrow doesn't roll away.

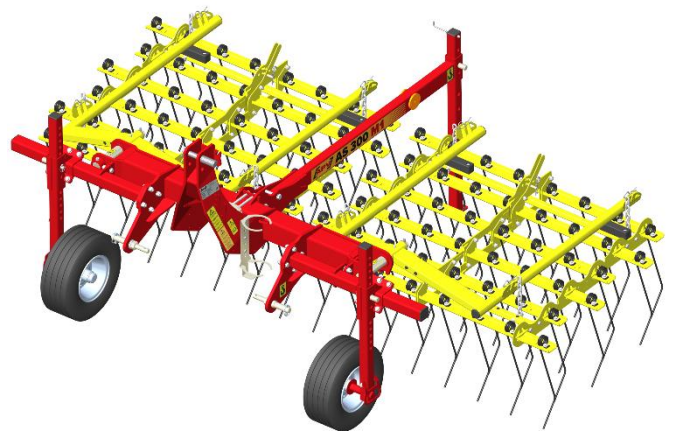

Figure 3: AS 300 M1

## 6.4 SAFE PARKING AS 450 / AS 600 M1 / AS 900 M1 RIGID

On implement version AS 450 (Figure 4), first fold down the rear parking support (as shown in Figure 8). The support leg must be secured with the spring cotter on the bolt to prevent accidental loosening.

On the implement versions AS 600 M1 (Figure 5) and AS 900 M1 rigid (Figure 6), you must first fold down the two parking supports (as shown in Figure 7). The rear parking stand must also be moved down. All of the stands must be secured with the spring cotter on the pin to prevent accidental loosening.

The parking area must be suitable for parking the implement, i.e. have a firm and level surface so that the stands do not sink in and the harrow doesn't roll away.

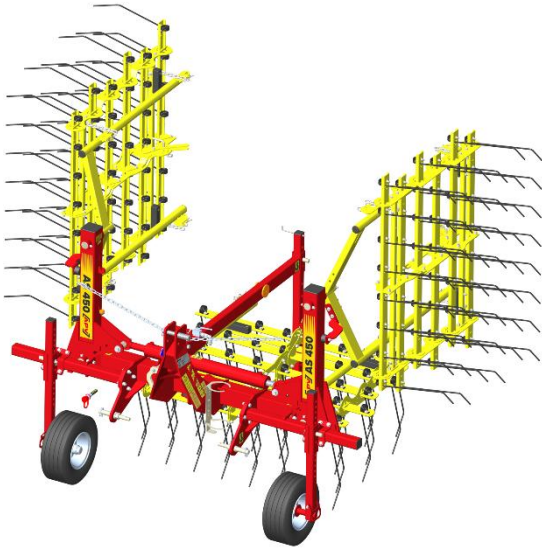

Figure 4: AS 450

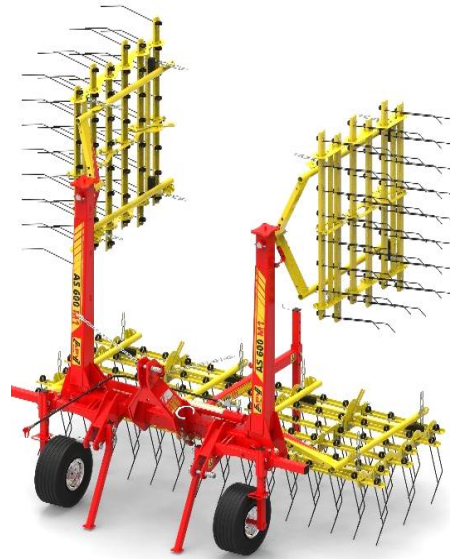

Figure 5: AS 600 M1



Figure 6: AS 900 M1 rigid

With hydraulic folding, the securing chain must be hooked onto the side wings and also lock the stop tap (if equipped), which is located on the folding cylinder. Then the pressure in the hydraulic hoses to the tractor must be relieved.



Figure 7: Front parking supports



Figure 8: Rear parking support

## 6.5 SAFE PARKING AS 900 M1 SCISSORS FOLDING / AS 1200 M1

To ensure safe parking for the implement versions AS 900 M1 scissors folding and AS 1200 M1 as well, the two rear parking supports on these versions must be taken out of the holders (Figure 9) and pushed into the hollow profile with the hole (Figure 8). The required height is selected using the pattern of holes on the outrigger, and pegged using pins. The pins are secured against unintentional loosening with a spring cotter.

Just like for the above-mentioned implement versions, the parking area must be suitable for parking the implement, i.e. have a firm and level surface so that the stands do not sink in and the weeder does not roll away.

Moreover, when parking the implement, it must be ensured that the two inner feeler wheels have sufficient tyre pressure (max. 3.4 bar), so that they do not develop flat tyres while they are parked.

With hydraulic folding, the securing chain must be hooked onto the side wings and also lock the stop tap (if equipped), which is located on the folding cylinder. Then the pressure in the hydraulic hoses to the tractor must be relieved.



Figure 9

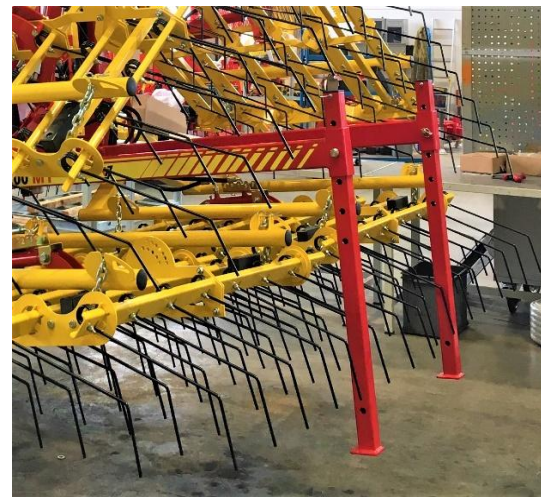

Figure 10

## 6.6 TEST FOLDING OF THE TINED WEEDER (WITH HYDRAULIC FOLDING)

### CAUTION!

Ensure that no one is standing in the danger area!

### CAUTION!

Fold the implement only when it is raised from the ground.

Proceed as follows for the test folding (unfolding and folding):

- 1) Couple the hydraulic line plugs. Ensure that they are always kept clean!
- 2) Afterwards, fill the cylinder with oil (fold the tined weeder together). The cylinders are filled as soon as the load on the securing chains are relieved.
- 3) Now unhook the securing chain.
- 4) When **folding** into transport position, the **implement** must also **be** lifted from the ground and the tines **may NOT be pre-tensioned**.
- 5) Fold the tined weeder together.
- 6) Hook the securing chain back in.
- 7) The tined weeder is now folded.

### CAUTION!

It is only permitted to fold the harrow when the harrow tines are retracted and **NOT** fully pre-tensioned.

### CAUTION!

In working position (during the entire working procedure), the tractor's control unit for the harrow's folding cylinder must be depressurised.

## 6.7 WORKING POSITION AND SETTING THE WORKING DEPTH

The working speed has a significant effect on the intensity of harrowing. The normal speed range is between 4 and 12 km/h, depending on the crop sensitivity and growth stage. Optimal results are already achieved starting at a speed of 6 km/h.

The tine position can be adjusted using the pattern of holes on each tine section (see Figure 11) and is pegged using a pin and cotter pin.

The 6 tine rows with a total of 48 tines and a line spacing of 31.25 mm per tine section ensure uniform harrow cultivation results.



Figure 11

### NOTE!

Ideally, there should almost be a right angle (90° - 100°) between the wearing end of the tine and the soil (see Figure 12 - centre). Because of the pre-tensioning, the right angle is only reached while driving.

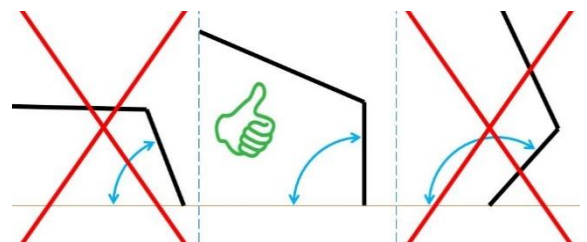



Figure 12: An angle of 90° - 100° is ideal



The feeler wheels are an important component for ground adaptation and therefore need to be properly adjusted. They can be moved on the frame according to the track width. The higher the position of the feeler wheels on the frame, the greater the working depth. The tine adjustment and the extended length of the top link have to be changed accordingly here as well.

All of the tine rows should penetrate the soil at the same depth to achieve a uniform working depth across the entire working width.

Depending on the soil type, more load can be applied to the tines through the frame and the sections by extending the top link. In doing so, the harrow frame and the tine section forks are tilted to the rear, and thus apply additional pressure to the tine sections.

To avoid damage here, plastic jaws are installed on the tine sections.

The chains for the tine sections must be hooked evenly on the tine section forks and secured with a spring cotter.



**CAUTION!**

When the harrow is lowered, do not allow it to push or roll back with the tractor; otherwise, the tines and tine sections can be severely damaged.



**CAUTION!**

Only set the harrow on the ground when the vehicle is already in motion. If the harrow is set down on the ground too rapidly at a standstill, there can be damage to the implement.



**CAUTION!**

After longer stretches of road transport or standstill, there can be differences in the hydraulic tine adjustment due to a change in temperature of the oil in the hydraulic lines. For this reason, tension the hydraulic tine adjustment completely and then relieve them again completely two times. Then you can set the desired tine position. This has to be done when the implement is lowered onto the ground.



**CAUTION!**

Driving in curves is not permitted. If it should be necessary after all, these curves must be driven in a very large radius.

## 6.8 HYDRAULIC TINE ADJUSTMENT

With the hydraulic tine adjustment (can be retrofitted for AS 450 to AS 1200 M1), a double-acting hydraulic cylinder is installed on each tine section. This allows the tine position to be changed while driving.

All of the hydraulic cylinders are connected by an oil circuit and are actuated in series. (Adjustments are made using a double-acting control unit). As a result, all of the hydraulic cylinders always have the same pressure.

When you lower the harrow until the tines of the tine sections are standing on the ground and you then actuate the double-acting control unit for the hydraulic tine adjustment, the oil pressure in the hydraulic cylinders of the respective tine sections is equalised among the sections and the tine pressure is adjusted evenly across the entire working width.



Figure 13

## 7 ROAD TRANSPORT

### 7.1 TRANSPORT ON PUBLIC ROADS (GENERAL INFORMATION)

- When driving on roads after field operation, the tine sections should be cleaned immediately of harrowing residues (soil, grass, etc.).
- Comply with the regulations of your country's legislation.
- The mounted implement must be identified with warning signs or stickers with red and white slanted lines (according to DIN, ÖNORM or respective STANDARDS) according to the regulations of the specific country.
- Any part posing a traffic hazard or dangerous parts (tines) must be covered and additionally identified with warning signs or stickers.
- Lighting equipment on the towing vehicle may not be hidden by the implement, otherwise they must be installed on the mounted implement.
- Warning signs or stickers should be visible at a height of max. 150 cm above the road when driving.
- The bracket for the warning signs (additional equipment) is mounted on the centre frame (see chapter 15 ).
- The axle load and the total weight of the towing vehicle may not be exceeded.
- The steering capacity of the tractor must not be impeded or reduced by the mounted implement!
- Semi-mounted implements may only be towed on public roads with an operating permit.
- Hydraulic implements must be folded in transport position.
- Ensure that the stop tap (if equipped) is closed or the securing chains are hooked.
- Only relieve the hydraulic hoses shortly before uncoupling the tractor by putting the tractor control unit into float position.
- Only relieve the hydraulic hose at home by putting the tractor control unit into float position.
- Also ensure that none of the safety splints were lost during operation.

### 7.2 CALCULATION OF THE WEIGHT RATIOS FOR AXLE LOADS ON THE TRACTOR AND BALLAST WEIGHTS

Implements mounted on the 3-point mounting change the total weight and the axle loads of the towing vehicle. These values may not exceed the permissible measures. The load-bearing capacity of the tyres must also be observed. The front axle of the tractor must be loaded with at least 20 % of the net weight of the tractor.

The necessary ballast weight as well as the actual axle loads can be determined using the following formulas:

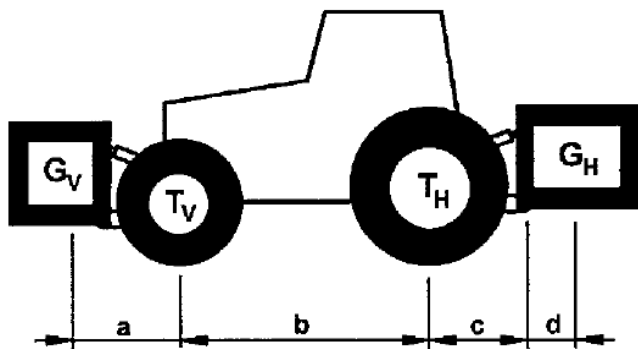

Figure 14

Specifications:

- $T_L$  Tractor net weight
  - $T_V$  Front axle load for the empty tractor
  - $T_H$  Rear axle load for the empty tractor
  - $G_H$  Total weight of the rear-mounted implement
  - $G_V$  Total weight of the front-mounted implement
  - a Distance from the centre of gravity of the front-mounted implement to the centre of the front axle
  - b Wheelbase of the tractor
  - c Distance from the centre of the rear axle to the centre of the lower link ball
  - d Distance from the centre of the lower link ball to the centre of gravity of the rear mounted implement
- ( $d_{AS\ 300} = 93\text{ cm}$ ,  $d_{AS\ 600} = 72\text{ cm}$ ,  $d_{AS\ 900} = 74\text{ cm}$ ,  $d_{AS\ 1200} = 105\text{ cm}$ )

## Weight calculations

1. Calculating the minimum front ballasting on rear-mounted implements  $G_{V\ min}$ :

$$G_{V\ min} = \frac{G_H \cdot (c + d) - T_V \cdot b + 0,2 \cdot T_L \cdot b}{a + b}$$

This result is entered in the following table.

2. Calculation of the minimum rear ballasting for front-mounted implements  $G_{H\ min}$ :

$$G_{H\ min} = \frac{G_V \cdot a - T_H \cdot b + 0,45 \cdot T_L \cdot b}{b + c + d}$$

This result is also entered in the table on page 19.

3. Calculation of the actual front axle load  $T_{V\ tat}$ :

If the required minimum front ballasting ( $G_{V\ min}$ ) is not reached with the front-mounted implement ( $G_V$ ), the weight of the front-mounted implement must be increased to the weight of the minimum front ballasting!

$$T_{V\ tat} = \frac{G_V \cdot (a + b) + T_V \cdot b - G_H \cdot (c + d)}{b}$$

Now enter the calculated actual front axle load and the permissible front axle load specified in the tractor operating manual in the following table.

4. Calculation of the actual total weight  $G_{tat}$ :

If the required minimum rear ballasting ( $G_H$ ) is not reached with the rear-mounted implement ( $G_H\ min$ ), the weight of the rear-mounted implement must be increased to the weight of the minimum rear ballasting!

$$G_{tat} = G_V + T_L + G_H$$

Now enter the calculated total weight and the permissible total weight specified in the tractor operating manual in the following table.

5. Calculation of the actual rear axle load  $T_{H\ tat}$ :

$$T_{H\ tat} = G_{tat} - T_{V\ tat}$$

Enter the calculated actual rear axle load and the permissible rear axle load specified in the tractor operating manual in the following table.

#### 6. Tyre load capacity:

Enter the doubled value (two tyres) for the permissible tyre load capacity (see e.g. tyre manufacturer documents) in the following table.

### CAUTION!

The minimum ballasting must be attached to the tractor as a mounted implement or ballast weight!

The calculated values may not be higher than the permissible values!

## 7.3 TABLE FOR THE WEIGHT RATIOS

	Actual value acc. to calculation		Permissible value acc. to operating manual		Double the permissible tyre load capacity (2 tyres)
Minimum ballast front/rear	kg				
Total weight	kg	≤	kg		kg
Front axle load	kg	≤	kg	≤	kg
Rear axle load	kg	≤	kg	≤	kg

## 8 MAINTENANCE AND CARE

### 8.1 GENERAL MAINTENANCE INSTRUCTIONS

To maintain the implement in good condition even after a long service life, the following instructions must be observed:

- In Point 4, you will find some basic safety regulations for maintenance work.
- Original parts and accessories are designed especially for the machines or implements.
- Please note that parts and accessories not supplied by us have also not been tested and approved by us.
- The installation or use of such products can therefore possibly negatively change or impede the constructional properties of your implement. The manufacturer rules out any liability for damages resulting from the use of non-original parts and accessories.
- The manufacturer is not liable for any unauthorised modifications to the implement and the use of components and auxiliary parts on the machines that were not purchased from APV.
- When replacing the hydraulic hose lines, original spare parts must be used that comply with the technical requirements of the implement manufacturer.
- Caution! Liquids escaping under high pressure can penetrate the skin. For this reason, a physician must be consulted immediately in case of accident!!!
- After cleaning, lubricate all of the grease points and distribute the grease evenly in the bearing points (e.g. perform a short test run).
- Do not use a high pressure cleaner to clean bearing and hydraulic parts.
- The paint can be damaged by cleaning with excessive pressure.
- During the winter, the implement should be protected against rust with an environmentally-friendly product.

- Park the implement protected from weather conditions.
- **Hydraulic hose lines must be replaced at the latest 6 years after their manufacturing date. The manufacturing date of the hydraulic hose lines is specified on the fittings.**
- Hydraulically as well as mechanically folded implement must only be parked in a folded state.
- Put down the implement in a way that the tines are not needlessly strained.
- Check the tyre pressure from time to time:  
Tyres 18x8.50: approx. 3 bar (AS 600 M1 – AS 1200 M1)  
Tyres 16x6.5: approx. 2.1 bar (AS 300 M1 – AS 450)

## 8.2 REGULAR MAINTENANCE WORK

- All bolted connections should be re-tightened at the latest after 3 operating hours and again after 20 hours, and then checked regularly. Loose bolts can cause significant consequential damage, which is not covered by the warranty.
- The grease points on the joints and bearings must be lubricated regularly (approx. every 10 operating hours with universal grease).
- After the first 10 operating hours and subsequently every 50 operating hours, the hydraulic units, hoses and couplings as well as tube lines must be checked for leaks and the bolted connections must be tightened if necessary.
- **Before every commissioning, check the hydraulic hose lines for wear, damage and ageing. Damaged or faulty parts must be immediately replaced.**
- The hydraulic system must be inspected at least once a year by specialist personnel.
- The platform kit and its access ladder must be visually inspected on a regular basis.



### NOTE!

When the implement is lifted off of the ground, the two side wings of the frame should be pointing slightly down. If this is not the case or if the wings are pointing down too much, the stop bolts on the joint or the setting screws for the stop on the junction between the inner and outer side frame must be adjusted.

## 8.3 CHANGING THE TINES

To change broken or worn tines:

- 1) Loosen the nut and pull the old tine out upwards.
- 2) Push in the new tine.
- 3) Fasten the new tine with the bolt (see Figure 15).
- 4) Ensure that the bolt rests firmly on the tine and that all tines form a straight line. The large flat washer should rest on the tine. Recommended tightening torque: 40 Nm.
- 5) The new tine is now installed.



Figure 15

## 8.4 REPAIRS AND SERVICE

In case of failure or damage to the Tined Weeder, please contact the manufacturer. The contact data can be found in chapter 2.

## 9 TECHNICAL DATA

Type designation:	AS 300 M1	AS 450	AS 600 M1	AS 900 M1	AS 900 M1 Scissors folding	AS 1200 M1
Mode of operation:	6 rows of round spring tines loosen the soil by lightly throwing up the earth in the 1-5 cm range					
Working width:	3 m	4.5 m	6 m	9 m	9 m	12 m
Transport width:	3 m for all models					
Dimensions [H x W x D in m], folded:	1.5 x 3 x 2.2	2.3 x 3 x 2.3	3 x 3 x 2.2	3.8 x 3 x 2.2	3.55 x 3 x 2.4	3.55 x 3 x 2.4
Working depth:	All models 0-30 mm (depending on the soil conditions)					
Number of tines [units]:	96	144	192	288	288	384
Line spacing:	31.25 mm for all models					
Mounting/hitch:	Mounting – CAT 1 / CAT 2		Mounting – CAT 2 / CAT 3N			
Net weight [kg]:	380	560	670	945	1,200	1,300
Working tools:	Round spring tines (Ø 6 / Ø 7 / Ø 8 mm)					
Ground adaptation:	Individual tine sections with a width of 1.5 m with chains hooked onto the frame. Oscillating bearing, enables ground adaptation					
Minimum tractor performance [kW/PS]:	22/30	33/45	44/60	51/70	58/80	58/80
Can be equipped with:	ES, MDP	MDP, PS 120 M1 – PS 200 M1	PS 120 M1 – PS 500 M2			

## 9.1 COMBINATION OPTIONS FOR THE TINED WEEDER WITH PNEUMATIC SEEDERS

PS	PS 120 E	PS 200 E	PS 200 H	PS 300 E	PS 300 H	PS 500 E	PS 500 H
Dimensions PS HxWxD [cm]	90x60x80	100x70x90	100x70x110	110x80x100	110x80x115	125x80x120	125x80x125
Weight [kg]	45	60	83	70	93	93	116
AS	Combined state: Dimensions HxWxD [cm] and weight [kg]						
AS450	230x300x230 780	230x300x230 795	230x300x230 818	Cannot be combined	Cannot be combined	Cannot be combined	Cannot be combined
AS600M1	300x300x220 890	300x300x220 905	300x300x220 928	300x300x220 915	300x300x220 938	300x300x280 938	300x300x280 961
AS900M1	Cannot be combined	Cannot be combined	380x300x280 1,208	Cannot be combined	380x300x280 1,218	Cannot be combined	380x300x280 1,241
AS900M1 scissor folding			355x300x300 1,468		355x300x300 1,478		355x300x300 1,501
AS1200M1			355x300x300 1,568		355x300x300 1,578		355x300x300 1,601

The mounting kits available for mounting PS on AS can be found in chapter 15 Accessories.

B: Width  
T: Depth

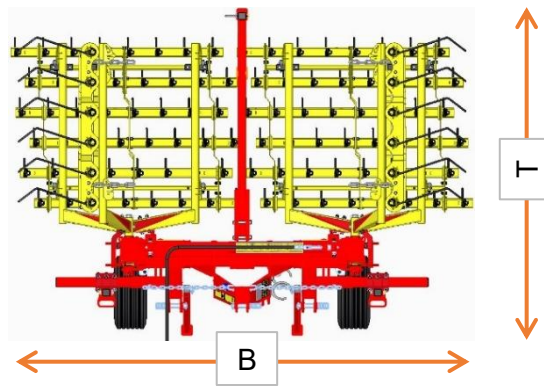

Figure 16: Tined weeder - Top view in transport position

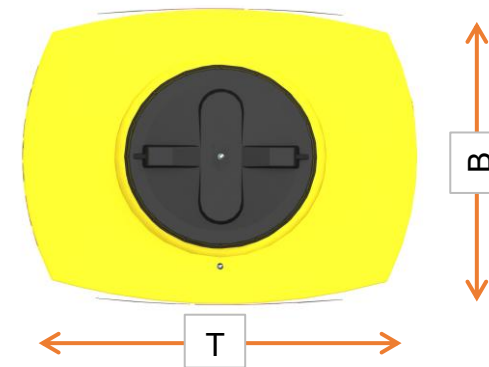

Figure 17: Pneumatic seeder - Top view

# 10 HYDRAULICDIAGRAM

## 10.1 AS 450, AS 600 M1, AS 900 M1 RIGID (SINGLE-ACTING)

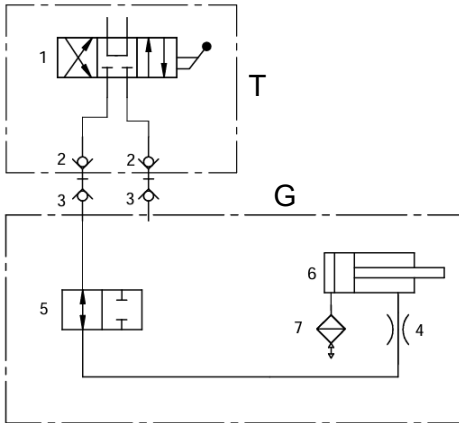

Figure 18

G	Implement-side	4	Throttle disc
T	Tractor-side	5	2/2-way ball valve
1	External control unit	6	Double-acting hydraulic cylinder for folding
2	Coupling sleeve BG 2	7	Vent valve
3	Coupling plug BG 2		

## 10.2 AS 450, AS 600 M1, AS 900 M1 RIGID (DOUBLE-ACTING)

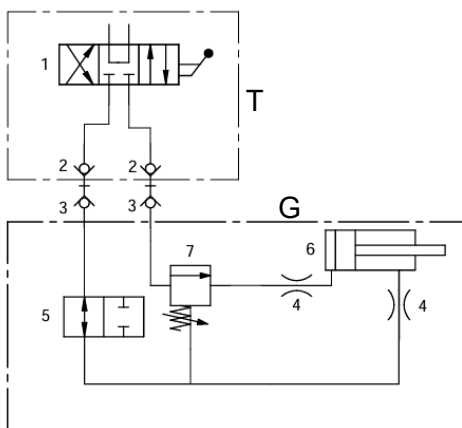
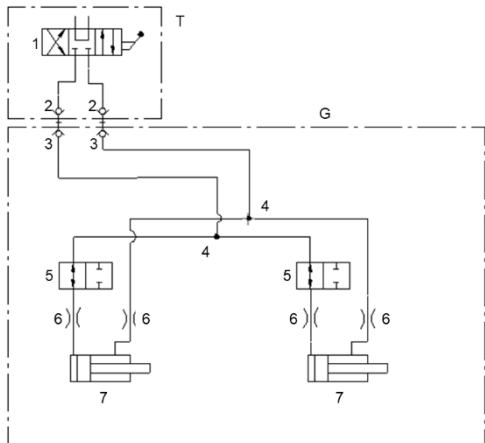

Figure 19

G	Implement-side	4	Throttle disc
T	Tractor-side	5	2/2-way ball valve
1	External control unit	6	Double-acting hydraulic cylinder for folding
2	Coupling sleeve BG 2	7	Pressure relief valve
3	Coupling plug BG 2		

## 10.3 AS 900 M1 SCISSORS FOLDING, AS 1200 M1



G	Implement-side	4	T-connection
T	Tractor-side	5	Locking block
1	External control unit	6	Throttle disc
2	Coupling sleeve BG 2	7	Double-acting hydraulic cylinder for folding
3	Coupling plug BG 2		

## 11 LIGHTING CIRCUIT DIAGRAM

### Legend:

R	Right
1	12 V plug, 7-pin
2	Rear light, right
2.1	Turn signal
2.2	Rear light
2.3	Brake light
L	Left
3	Rear light, left
3.1	Brake light
3.2	Rear light
3.3	Turn signal

### Plug and cable assignment:

No.	Desig.	Colour	Function
1	L	Yellow	Turn signal, left
2	54g	---	---
3	31	White	Earth
4	R	Green	Turn signal, right
5	58R	Brown	Rear light, right
6	54	Red	Brake light
7	58L	Black	Rear light, left

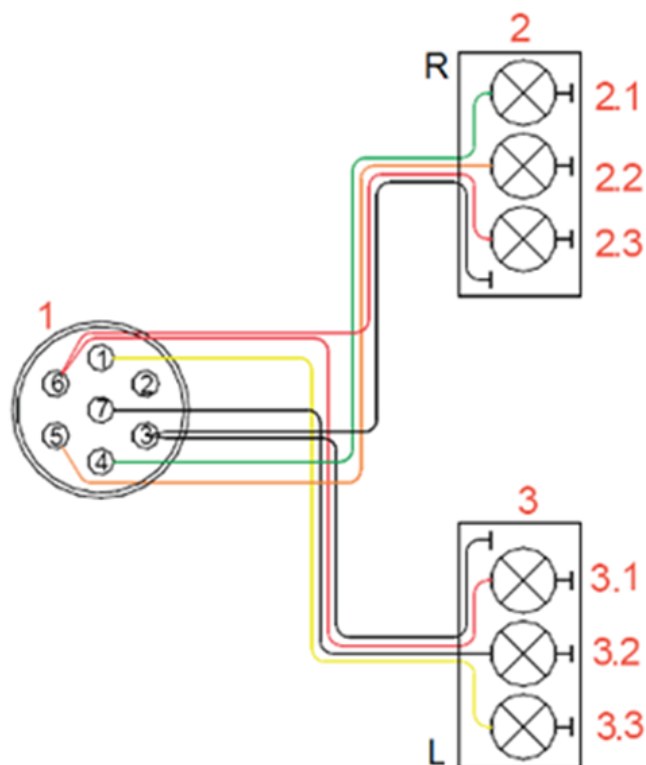

Figure 20



## **12 DECOMMISSIONING, STORAGE AND DISPOSAL**

### **12.1 DECOMMISSIONING THE IMPLEMENT**

To ensure that the implement remains fully functional even if it is out of operation for longer periods of time, it is important to take precautions for storage:

The corresponding instructions for safe and proper parking of each implement version can be found under points 6.3 to 6.5.

### **12.2 STORAGE OF THE IMPLEMENT**

- The implement must be stored in a dry place protected from weather conditions to ensure that it remains functional even if it is stored for a longer period of time.
- The implement must be parked in compliance with Point 6.3 to 6.5.
- Secure the implement against unintentional rolling away.
- Nothing may be deposited or stored on the implement.
- The implement must always be parked and stored in a secure area, to prevent unauthorised operation.

### **12.3 DISPOSAL**

Disposal of the implement must be performed according to the local disposal regulations for machines.

## 13 CROPPING TIPS FOR USING THE TINED WEEDER

The harrow's mode of action mainly consists of burying and uprooting the weeds and crumbling the soil surface. It also stimulates tillering in cereals. Compared to field hoes, the Tined Weeder has two big advantages: It works independently of the rows and has a comparatively high area output.

The seed rate and surface structure of the seedbed are very closely related to the success of harrowing against weeds. Whereby shallow seeding excludes any pre-emergence harrowing. When the plants are firmly rooted in the soil later on, harrowing can be performed again. At seeding depths of 3-4 cm, pre-emergence harrowing is possible when the working depth of the harrow is shallower. However, the germinating seed may not be touched by the harrow tines during operation.

In general, the objective is to control weeds by harrowing at the germination phase during the growing season while protecting the crops as much as possible. The optimal mode of operation to achieve this strongly depends on the soil, crop, and weather conditions. The optimal site-dependent mode of operation can be found fastest by adjusting the working depth and varying the working speed. As a basic setting on the harrow, the tips of the tines should be about vertical to the soil surface.

Warnings against excessive harrowing intensity include uprooted, buried or bent plants to an extent of more than 10% of the crop. Low crop losses can be compensated in advance through a slight increase in the seed rate. After finishing all field passes, the final crop density should not drop below the cropping-related required values.

Other effects of tilling your fields with the tined weeder, such as

- Soil aeration,
- Regulation of the water balance,
- Incorporation of the seed for nurse crops and
- Promoting tillering in cereals

make a significant contribution to the formation of good crops.

Summary for efficient and effective harrowing:

- Important prerequisites are a level seedbed, sufficiently deep seed placement, uniform germination, loose soil surface, few tracks, and dry weather.
- A missed harrowing pass can NOT be performed at a later date.
- Harrowing does not have a lasting effect => several consecutive work passes must be coordinated.
- Optimal harrowing takes place at the limit of crop tolerance, in case of doubt, enumerate the crop plant losses.
- When seeding, account for crop plant losses.
- The weed-controlling effect of the harrow is sometimes already achieved at low forward speeds (above approx. 2 km/h).
- Optimal adjustment of the harrow can take a lot of time.

Only the potential of harrowing is described here! Ultimately, harrowing success depends on the skill and experience of the operator.

## 14 INFORMATION ON NATURE CONSERVATION AND ENVIRONMENTAL PROTECTION

### 14.1 REDUCTION OF NOISE POLLUTION DURING USE

Any loose parts (e.g. chains) should be attached to prevent unnecessary noise.

### 14.2 ENERGY-EFFICIENT USE

The tines of the Tined Weeder should not penetrate into the field deeper than necessary. By doing so, the towing vehicle is not unnecessarily strained and fuel can be saved.

### 14.3 RECYCLABLE RAW MATERIALS DURING DISPOSAL

Many parts of the Tined Weeder are made of steel or spring steel (such as the centre frame, side frame, tine section, tines, ...) and can be accepted and recycled by a waste disposal plant.

## 15 ACCESSORIES

### 15.1 WARNING SIGNS AND LED LIGHTING

For the tined weeder, warning signs with LED lighting are also available as an accessory. These are required when you want to drive with the Tined Weeder on public roads.

Order number:

07042-2-001015 (AS 450)

07016-2-057 (AS 300 M1, AS 600 M1, AS 900 M1)

07015-2-140 (AS 1200 M1)

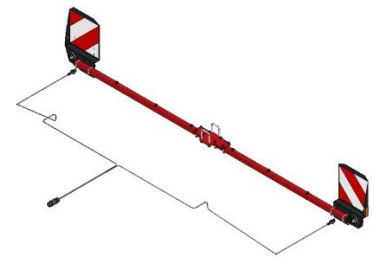

Figure 21

### 15.2 ACCESSORIES KIT AS 600 TO AS 900

With this accessories kit, the AS 600 M1 can be extended to an AS 900 M1. The working width is therefore increased from 6 m to 9 m.

Order number:

07017-2-009



Figure 22

### 15.3 ACCESSORIES KIT AS 900 TO AS 1200

With this accessories kit, the AS 900 M1 scissors folding can be extended to an AS 1200 M1. The working width is therefore increased from 9 m to 12 m.

Order number

07021-2-010



Figure 23

## 15.4 ACCESSORIES KIT FOR PS 120 – 300

Is used to mount a pneumatic seeder on the tined weeder. Please note that it must be mounted in compliance with the standards.

Order number:

07042-2-001025 (AS 450) (PS 300 not possible)

07017-2-006 (AS 600 M1)

07016-2-031 (AS 900 M1) (PS 300 not possible)

07021-2-018 (AS 900 M1 scissors folding)



Figure 24: Symbolic image

## 15.5 ACCESSORIES KIT FOR ES AND MDP

Used to mount a Single Disc Spreader ES or an MDP Multi-Metering System on the AS 300 M1 tined weeder. Please note that it must be mounted in compliance with the standards.

Order number:

07034-2-007 (AS 300 M1)

07042-2-001026 (AS 450) (ES not possible)

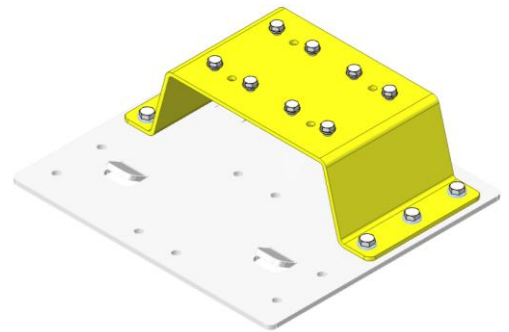

Figure 25

## 15.6 ACCESSORIES KIT FOR PS 120 – 500 WITH HEADSTOCK

In combination with the headstock, it serves for elevated mounting of a pneumatic seeder on the tined weeder. Please note that it must be mounted in compliance with the standards.

Order number headstock:

07015-2-018

Order number accessories kit for PS 120 – 500:

07017-2-007 (AS 600 M1)

07016-2-032 (AS 900 M1)

07021-2-019 (AS 900 M1 scissors folding)

07015-2-017 (AS 1200 M1)



Figure 26: Headstock



Figure 27: Symbolic image, accessories kit for PS 120 – 500

## 15.7 HYDRAULIC TINE ADJUSTMENT

For the hydraulic adjustment of the tine position, e.g. while driving.

Order number:

07042-2-001027 (AS 450)

07017-2-004 (AS 600 M1)

07016-2-030 (AS 900 M1)

07021-2-006 (AS 900 M1 scissors folding)

07015-2-016 (AS 1200 M1)



Figure 28

## 15.8 PLATFORM KIT FOR AS

For easier maintenance of the pneumatic seeder, a suitable platform kit is available for each PS accessories kit (see item 15.4 and 15.6).

Please note that it must be mounted in compliance with the standards.

Order number:

For PS accessories kit without headstock (see item 15.4):

07016-2-052 (AS 300 M1, AS 600 M1, AS 900 M1)

07042-2-001024 (AS 450)

For PS accessories kit with headstock (see item 15.6):

07016-2-053 (AS 600 M1, AS 900 M1)

07015-2-107 (AS 900 M1 scissors folding, AS 1200 M1)



Figure 29: Symbolic image, platform kit for accessories kit for PS without headstock

Figure 30: Symbolic image, platform kit for accessories kit for PS with headstock

## 15.9 ACCESSORIES KIT FOR A SECOND FEELER WHEEL PAIR

Additional feeler wheel pair for the side frames.

Order number:

07017-2-005 (AS 600 M1)



Figure 31

## 16 SPARE PARTS

You have the option to order your required spare parts directly through our online spare parts catalogue. To do so, scan the QR code with your smartphone - you will be taken directly to our online spare parts catalogue. Please keep your product number / serial number at hand.

You can also view our online spare parts catalogue on our website [www.apv.at](http://www.apv.at) in the Service area.



If you have any questions regarding spare parts or your order, our Customer Service (see point 2 for contact data) is also happy to assist you.

# 17 INDEX

Accessories .....	28	Nature conservation and environmental protection .....	27
Bearing .....	26	Operating manual .....	12
Calculation of the weight ratios .....	17	Parking .....	12, 13, 14
Changing the tines .....	20	Plug and cable assignment .....	25
Combination options .....	22	Repairs and service .....	20
Dangers .....	9	Road transport .....	17
Decommissioning .....	26	Safety information .....	6
Disposal .....	26	Safety signs .....	9
Driving in curves .....	16	Safety-related instructions and accident prevention regulations .....	7
Energy-efficient use .....	28	Service .....	5
Feeler wheel pair .....	30	Spare parts .....	30
Folding .....	15	Spare parts orders .....	5
Guide wheels .....	16	Sticker .....	9
Hydraulic cylinders .....	17	Table for the weight ratios .....	19
Hydraulic diagram .....	24	Technical data .....	21
Hydraulic system .....	8	Tine position .....	15
Hydraulic tine adjustment .....	17, 30	Tips .....	27
Identification of the implement .....	5	Type plate .....	5
Implement description .....	12	Tyres .....	9
Intended use .....	6	Warning signs .....	28
Maintenance .....	9	Warranty .....	6
Maintenance and care .....	19	Warranty claims .....	5
Maintenance and servicing work .....	5	Weight calculations .....	18
Minimum ballasting .....	18	Working depth .....	15
Mode of operation .....	21	Working position .....	15
Mounted implements .....	8	Working speed .....	15
Mounting on the tractor .....	12		
Multi-Metering System .....	29		





---

**APV – Technische Produkte GmbH**  
Zentrale: Dallein 62  
AT - 3753 Hötzelndorf

Tel.: +43 2913 8001  
office@apv.at  
www.apv.at

